

POWERED SWING IN CHUTE FOR EMPTYING CLEARING CHAMBER

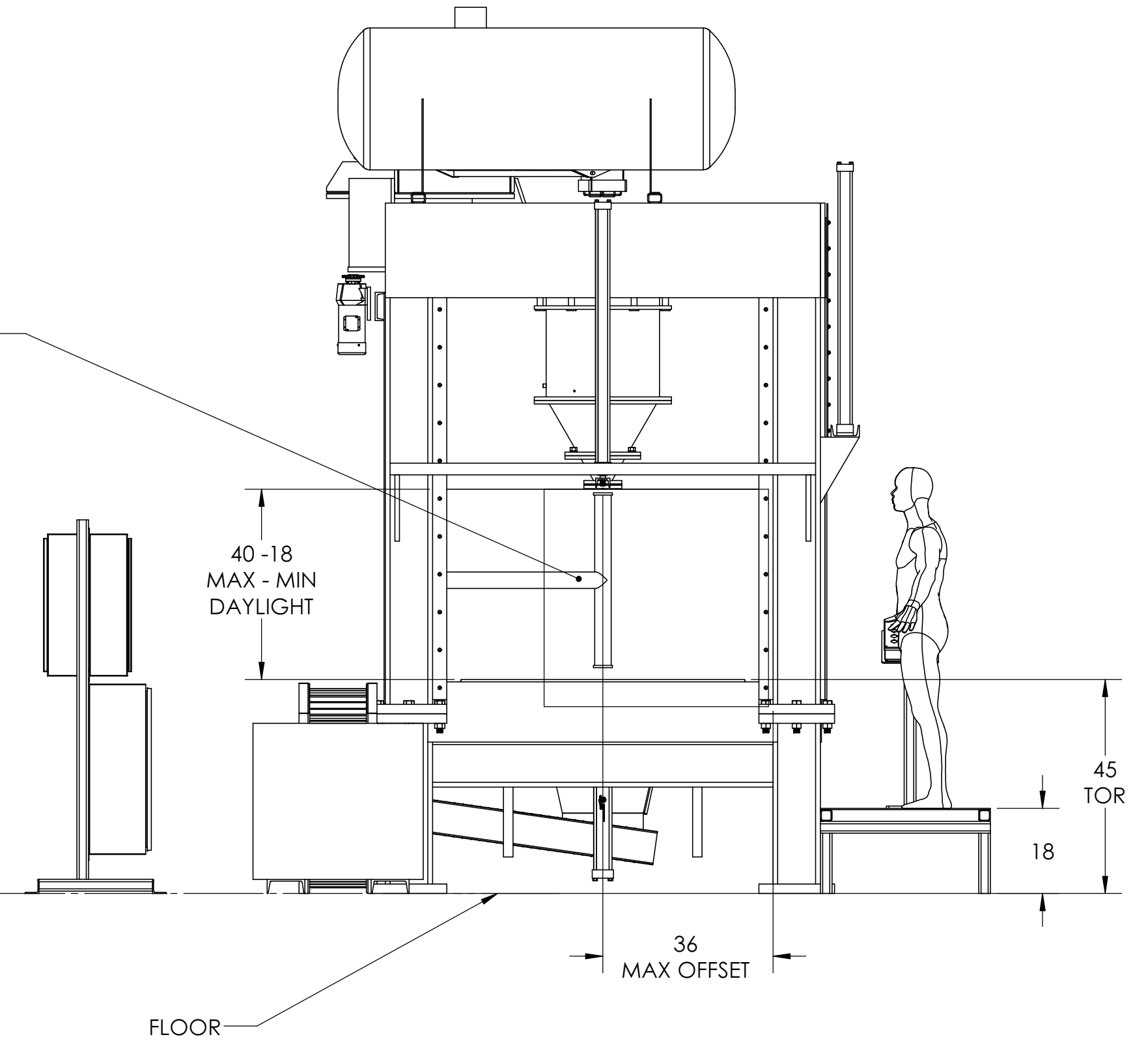

CUSTOMER APPROVAL
SIGNATURE: _____
DATE: _____

REV		ECH	DATE	UNLESS OTHERWISE SPECIFIED:		NAME	DATE
				DIMENSIONS ARE IN INCHES		DRAWN	07/04/2013
				TOLERANCES:		APPROVED	
				FRACTIONAL ±1/16		NOTE	
				ANGULAR MATCH ±1		MATERIAL	
				ONE PLACE DECIMAL ±.150		FINISH	
				TWO PLACE DECIMAL ±.030		WEIGHT	
				THREE PLACE DECIMAL ±.005		PART NO.	

PROPRIETARY AND CONFIDENTIAL - THE INFORMATION CONTAINED IN THIS DRAWING IS THE SOLE PROPERTY OF PALMER MANUFACTURING. ANY REPRODUCTION IN PART OR AS A WHOLE WITHOUT THE WRITTEN PERMISSION OF PALMER MANUFACTURING IS STRICTLY PROHIBITED.

PALMER 18 BECHTLE AVE
 SPRINGFIELD, OH 45504 U.S.A.
 (937) 323-6339
 (800) 427-5454

TITLE: CM-300 COREMAKER
 SIZE: D DWG. NO.: CM10230 REV: B
 SCALE: 1:28 DO NOT SCALE SH1 1 OF 2

D CM10230-Rev B